

ADS-464 List Of Standard Features

- Automatic Drying Cycle (U.S. Patent No. 4,827,627)
 - Lint Drawer System. Lint Filtered Out Prior to the Fan
 - Stainless Steel Basket (175 cu. ft. Volume)
 - 2.8 Million Btu's of Heat Input
 - 13,000 cfm Airflow
 - S.A.F.E. (Sensor Activated Fire Extinguishing system) with Integrated Safety Switches and Horn Alarm
 - Automatic Air Jet Cleans Blower Wheel After Every Cycle
 - Rotational Sensor Adds an Extra Element of Safety
 - Unique Anti-Wrinkle Feature
 - Computer Controls with Preprogrammed Cycles (Manual Overrides) and Celsius or Fahrenheit Programmability
 - Self-Diagnostic Computer
 - Multilingual Display Capabilities
 - One 7-1/2 hp Drive Motor
 - 11" Diameter Drive Wheels
 - Front and Rear Axial Basket Stabilizers
 - Can be Integrated with an Automatic Conveyor System
 - Automatic Programmable Cool Down
 - Fully Insulated Stainless Steel Burner Chamber
 - Fully Insulated Load Doors
 - Automatic Heat Recirculation
 - Automatic Forced Air Gas Burner
 - Industrial Grade, Locking, Multi-Pin Plugs for Quick Connect/Disconnect
 - Modular Design for Ease of Shipping and Reassembly
 - 60 or 50 Hz Power, 208-480V, 3-Phase, 3- or 4-Wire
 - "End of Cycle" Flashing Indicator
 - Redundant Gas Valves for Safety
 - Quiet, Reliable, Belt-Driven Fan
 - Totally Enclosed Motors
 - Steam Damper Temperature Control
-
- AGA/CGA Option Available
 - Optional Poly/Teflon®-Coated Basket

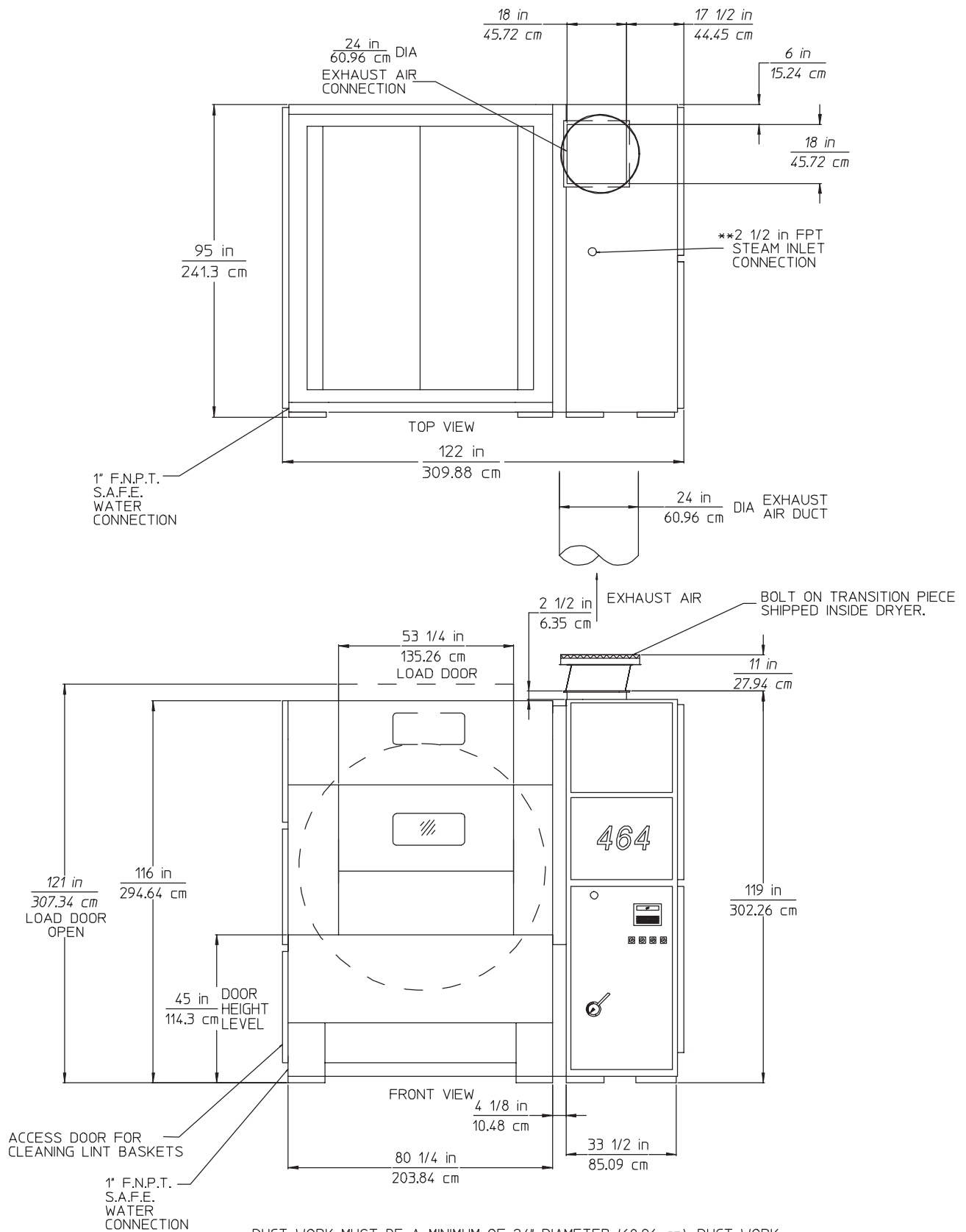

*DUCT WORK MUST BE A MINIMUM OF 24" DIAMETER (60.96 cm). DUCT WORK SIZE VARIES WITH INSTALLATION CONDITIONS. EXHAUST STATIC PRESSURE SHOULD NOT EXCEED 1.25" WATER COLUMN (3.1 mbar).

ADS-464 Shipping Dimensions		
ONE PIECE	132"L x 100"W x 132"H	335.3 x 254 x 335.3 cm
Skidded Weight	11,162 lb	5,063.08 kg
Volume	941 cu ft	26.65 cu m
TWO PIECES		
Base and Main Frame	86-3/8" x 100" x 132"	219.39 x 254 x 335.3 cm
Skidded Weight	7,000 lb	3,175.2 kg
Volume	660 cu ft	18.69 cu m
Control Module	40-1/8" x 100" x 132"	101.92 x 254 x 335.3 cm
Skidded Weight	3,720 lb	1,687.39 kg
Volume	306.5 cu ft	8.68 cu m
FOUR PIECES		
Base	88" x 89" x 41"	223.5 x 226 x 104.1 cm
Skidded Weight	2,250 lb	1,020.6 kg
Volume	186 cu ft	5.27 cu m
Main Frame	94" x 89" x 90"	238.76 x 226 x 228.6 cm
Skidded Weight	4,600 lb	2,086.56 kg
Volume	436 cu ft	12.35 cu m
Control Module		
Upper Console	90" x 40" x 83"	241.3 x 101.6 x 210.8 cm
Skidded Weight	2,165 lb	982.04 kg
Volume	173 cu ft	4.90 cu m
Lower Console	95" x 40" x 67"	241.3 x 101.6 x 170.2 cm
Skidded Weight	1,800 lb	816.48 kg
Volume	146 cu ft	4.13 cu m

Shaded areas are stated in metric equivalents.

Specifications subject to change without notice.

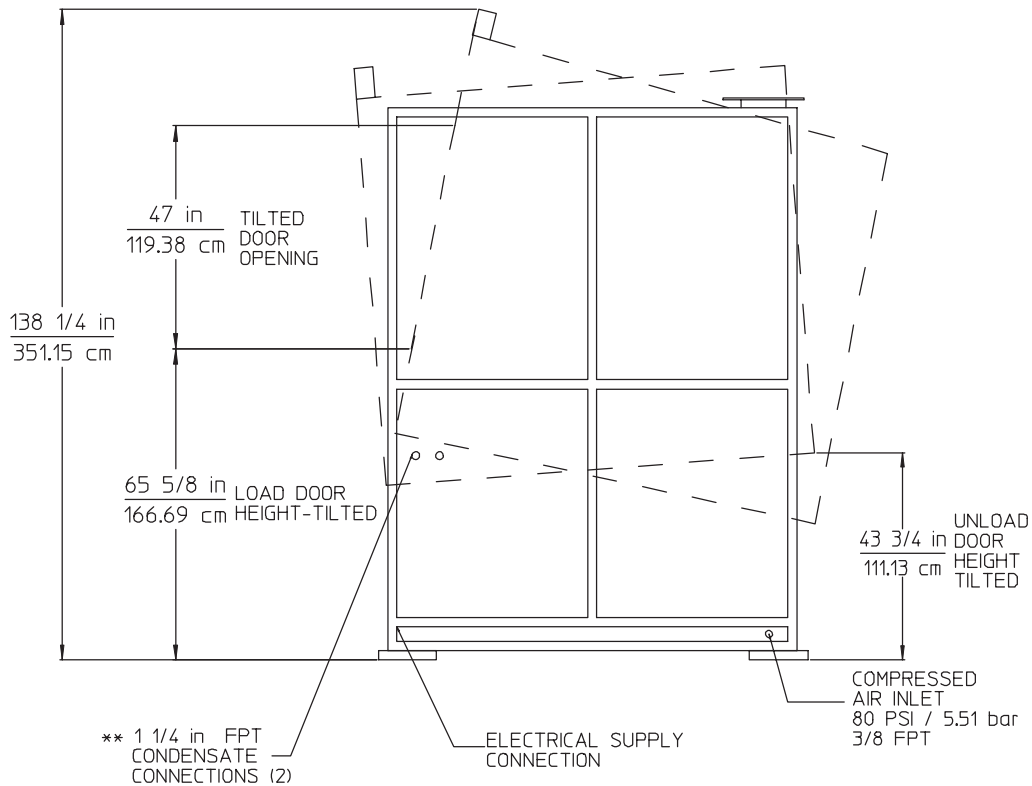

** SIZE OF PIPING TO DRYER VARIES WITH INSTALLATION CONDITIONS. CONTACT FACTORY FOR ASSISTANCE.

ADS-464 SPECIFICATIONS	460 lb	Metric Equivalents 209.09 kg
Total Weight	11,000 lb	4,989.6 kg
Total Shipping Weight (stretch wrap/skid)	11,162 lb	5,063.08 kg
Tilt Height	138-1/4"	351.12 cm
Operating Height	116"	294.64 cm
Full Tilt Depth	117-1/2"	298.45 cm
Operating Depth	95"	241.3 cm
Width	122"	309.88 cm
Tilt Load (rear tilt)	15°	15°
Tilt Unload (front tilt)	15°	15°
Unloading Height from Floor	43-3/4"	111.13 cm
Loading Height from Floor	65-5/8"	166.69 cm
Door Opening*	53-1/4" w x 49" h	135.26 x 124.46 cm
Basket Diameter	69-1/8"	175.58 cm
Basket Depth	80-5/16"	203.99 cm
Basket Volume	175 cu ft	4.96 cu m
Minimum Load Size	250 lb	113.64 kg
Maximum Load Size	460 lb	209.09 kg
Boiler Horsepower	60 Bhp	
Steam Inlet Connection Size **	2-1/2" F.P.T.	
Steam Return Connection Size ** (2 places)	1-1/4" F.P.T.	
Blower Motor	25 hp	18.65 kW
Drive Motor	7-1/2 hp	5.6 kW
Airflow	13,000 cfm	368 cmm
Maximum Duct Back Pressure	1.25" (wc)	3.1 mbar
Minimum Duct Diameter**	24"	60.96 cm
Compressed Air Pressure Required	80 psi (± 10 psi)	5.5 bar (± 0.69)
Compressed Air Volume Required (1-way / 2-way tilt)	16 / 20 cfm	0.45 / 0.57 cmh
Compressed Air Connection	3/8" F.N.P.T.	
S.A.F.E. Water Connection	1" F.N.P.T.	

Shaded areas are stated in metric equivalents.

* Height is 49" (124.46 cm) maximum at the center of the door.

** Size of piping to dryer varies with installation conditions. Contact factory for assistance.

Steam Electrical Service Specifications (Per Dryer)†					
IMPORTANT: 208 VAC and 230/240 VAC are not the same. When ordering, specify exact voltage.					
NOTES: A. Circuit breakers are thermal/magnetic (industrial) motor curve type ONLY . For others, calculate/verify correct breaker size according to appliance amp draw rating and type of breaker to be used.					
. B. Circuit breakers for 3ø dryers must be 3-pole type.					
Service Voltage	Phase	Wire Service	Approx. Amp Draw		Circuit Breaker Amperage
			60 Hz	50 Hz	
208	3	3/4	106	-	150
230	3	3	100	105	150
380	3	3/4	-	60	90
400	3	3/4	-	59	90
416	3	3/4	-	58	90
460/480	3	3	53	-	80

