



AD-310

MAXIMUM CAPACITY (DRY WEIGHT)		310 lb	140.61 kg
MINIMUM LOAD SIZE		205 lb	92.99 kg
TUMBLER DIAMETER		62-1/2"	158.75 cm
TUMBLER DEPTH		60"	152.40 cm
TUMBLER VOLUME		106.50 cu ft	3015.744 L
DOOR OPENING (WIDTH X HEIGHT)		36-3/4" x 43"	93.35 cm x 109.22 cm
DOOR SILL HEIGHT, LEVEL		36-1/2"	92.71 cm
DOOR SILL HEIGHT, REAR TILT		53"	134.62 cm
DOOR SILL HEIGHT, FRONT TILT		33-1/2"	85.09 cm
CABINET OPERATING DEPTH, LEVEL (1 DOOR/2 DOOR)		72-3/4" / 78"	184.79 cm / 198.12 cm
CABINET WIDTH		82-1/2"	209.55 cm
REAR TILT		15°	
FRONT TILT		15°	
WATER CONNECTION		3/4" F.N.P.T.	
Gas	CABINET REAR TILT HEIGHT	122-7/16"	310.99 cm
	CABINET OPERATING HEIGHT, LEVEL	114-1/4"	290.20 cm
	CABINET FULL TILT DEPTH	116-7/16"	295.75 cm
	APPROX. NET WEIGHT	5,000 lb	2,267.96 kg
	APPROX. SHIPPING WEIGHT	5,310 lb	2,408.58 kg
	VOLTAGE AVAILABLE	208-575v 3ø 3,4w 50/60 Hz	
	TUMBLER/DRIVE MOTOR	5 hp	3.73 kW
	BLOWER/FAN MOTOR (REAR/SIDE EXHAUST)	15 hp / 25 hp	11.19 kW / 18.64 kW
	BURNER BLOWER MOTOR	N / A	
	BURNER TYPE	On / Off	
	HEAT INPUT	1,125,000 Btu/hr	283,495 kcal/hr
	INLET PIPE CONNECTION (NON-TILT/TILT)	(2) 1-1/2 M.N.P.T. / 1-1/2" M.N.P.T.	
	MAXIMUM GAS PRESSURE	12 in WC	29.89 mb
	AIRFLOW	6,500 cfm	184.06 cmm
	MAXIMUM EXHAUST BACK PRESSURE	0.3 in WC	0.75 mb
	EXHAUST DIAMATER	24"	60.96 cm
	COMPRESSED AIR PRESSURE	80 psi (± 10 psi)	5.52 bar (± 0.69 bar)
	COMPRESSED AIR VOLUME (1-WAY/2-WAY TILT)	11 cfh / 11 cfh	0.31 cmh / 0.31 cmh
COMPRESSED AIR CONNECTION (NON-TILT/TILT)	3/8" F.N.P.T. / 3/8" Quick Connection		
Steam	CABINET REAR TILT HEIGHT	127-1/2"	323.85 cm
	CABINET OPERATING HEIGHT, LEVEL	126-1/2"	321.31 cm
	CABINET FULL TILT DEPTH	113-7/16"	288.13 cm
	APPROX. NET WEIGHT	5,425 lb	2,460.74 kg
	APPROX. SHIPPING WEIGHT	5,735 lb	2,601.35 kg
	VOLTAGE AVAILABLE	208-575v 3ø 3,4w 50/60 Hz	
	TUMBLER/DRIVE MOTOR	5 hp	3.73 kW
	BLOWER/FAN MOTOR	25 hp	18.64 kW
	BOILER HORSEPOWER (NORMAL LOAD)	35 Bhp	
	SUPPLY CONNECTION	2" M.N.P.T.	
	RETURN CONNECTION (NON-TILT/TILT)	2" M.N.P.T. / 1-1/4" M.N.P.T.	
	STEAM CONSUMPTION	1,153 lb/hr	522.99 kg/hr
	AIRFLOW	8,500 cfm	240.69 cmm
	MAXIMUM EXHAUST BACK PRESSURE	0.3 in WC	0.75 mb
	EXHAUST DIAMETER	24"	60.96 cm
	COMPRESSED AIR PRESSURE	80 psi (± 10 psi)	5.52 bar (± 0.69 bar)
	COMPRESSED AIR VOLUME (1-WAY/2-WAY TILT)	11 cfh / 11 cfh	0.31 cmh / 0.31 cmh
	COMPRESSED AIR CONNECTION (NON-TILT/TILT)	3/8" F.N.P.T. / 3/8" Quick Connection	

Shaded areas are stated in metric equivalents

EV 9/24/04

310* NON-TILT GAS MODEL

* BOTH GAS AND STEAM TILTING UNITS MUST BE SUPPLIED WITH CLEAN, DRY, REGULATED AIR AT 80 PSI +/- 10 PSI (5.52 BAR +/- 0.62 BAR)
 ** DUCTWORK SIZE VARIES WITH INSTALLATION CONDITIONS, EXHAUST STATIC PRESSURE SHOULD NOT EXCEED 0.3" WATER COLUMN (0.74 INH)
 *** SIZE OF PIPING TO DRYER VARIES WITH INSTALLATION CONDITIONS, CONTACT FACTORY FOR ASSISTANCE
 **** THE FIRE SUPPRESSION SYSTEM MUST BE SUPPLIED WITH WATER AT A PRESSURE OF 40 PSI MIN/100 PSI MAX. (2.8 BAR MIN/6.9 BAR MAX.)

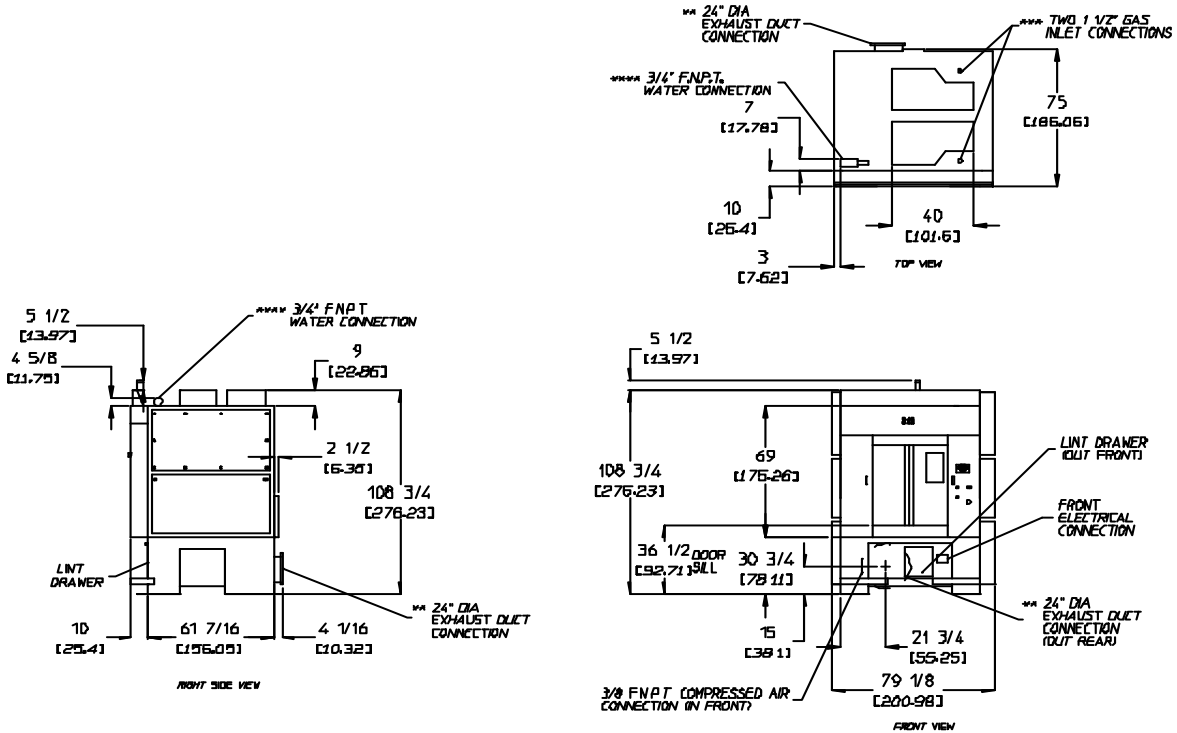

310* NON-TILT STEAM MODEL

* BOTH GAS AND STEAM TILTING UNITS MUST BE SUPPLIED WITH CLEAN, DRY, REGULATED AIR AT 80 PSI +/- 10 PSI (5.52 BAR +/- 0.62 BAR)
 ** DUCTWORK SIZE VARIES WITH INSTALLATION CONDITIONS, EXHAUST STATIC PRESSURE SHOULD NOT EXCEED 0.3" WATER COLUMN (0.74 INH)
 *** SIZE OF PIPING TO DRYER VARIES WITH INSTALLATION CONDITIONS, CONTACT FACTORY FOR ASSISTANCE
 **** THE FIRE SUPPRESSION SYSTEM MUST BE SUPPLIED WITH WATER AT A PRESSURE OF 40 PSI MIN/100 PSI MAX. (2.8 BAR MIN/6.9 BAR MAX.)

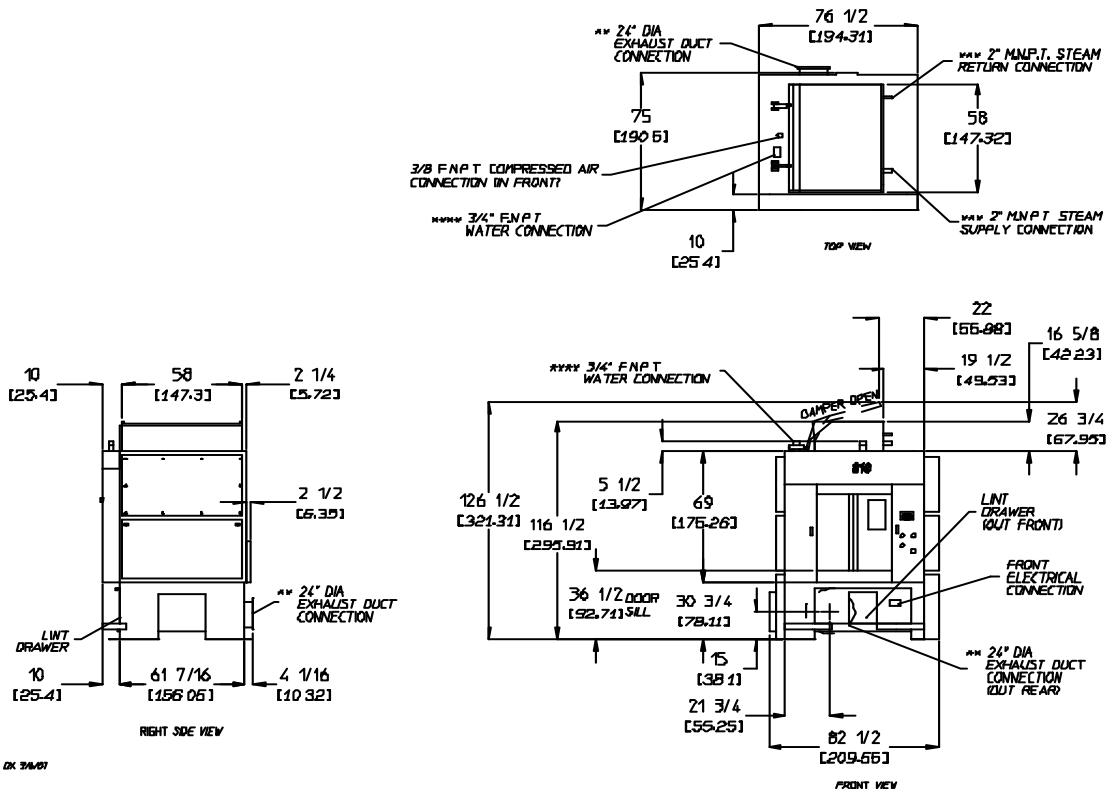

310 TILTING* 1 DOOR/FORWARD TILT GAS MODEL

- * BOTH GAS AND STEAM TILTING UNITS MUST BE SUPPLIED WITH CLEAN, DRY, REGULATED AIR AT 80 PSI * 10 PSI (5.52 BAR * .69 BAR)
- ** DUCTWORK SIZE VARIES WITH INSTALLATION CONDITIONS; EXHAUST STATIC PRESSURE SHOULD NOT EXCEED 0.3" WATER COLUMN (0.74 #/sq)
- *** SIZE OF PIPING TO DRYER VARIES WITH INSTALLATION CONDITIONS; CONTACT FACTORY FOR ASSISTANCE

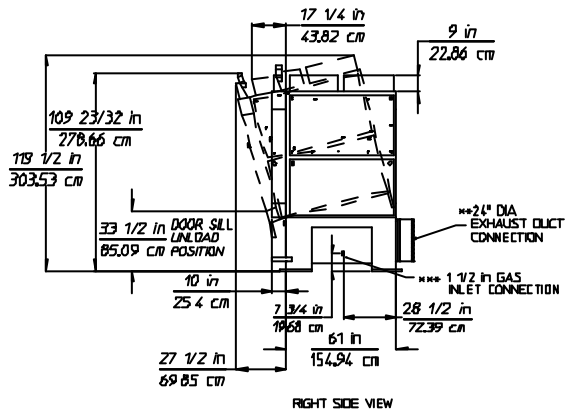
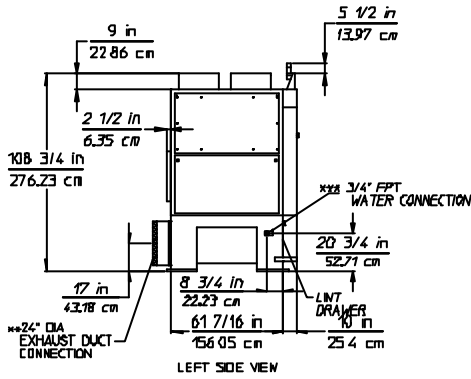
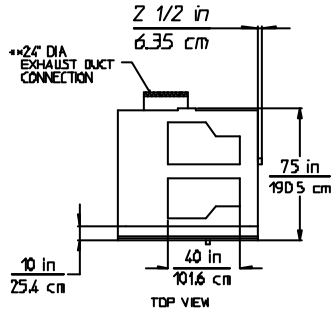
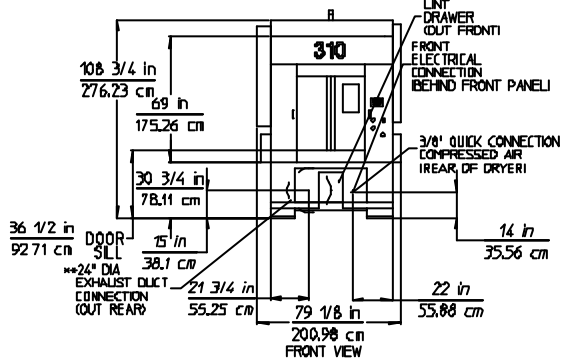

DX 3/16/1

310 TILTING* 1 DOOR/FORWARD TILT STEAM MODEL

- * BOTH GAS AND STEAM TILTING UNITS MUST BE SUPPLIED WITH CLEAN, DRY, REGULATED AIR AT 80 PSI * 10 PSI (5.52 BAR * .69 BAR)
- ** DUCTWORK SIZE VARIES WITH INSTALLATION CONDITIONS; EXHAUST STATIC PRESSURE SHOULD NOT EXCEED 0.3" WATER COLUMN (0.74 #/sq)
- *** SIZE OF PIPING TO DRYER VARIES WITH INSTALLATION CONDITIONS; CONTACT FACTORY FOR ASSISTANCE

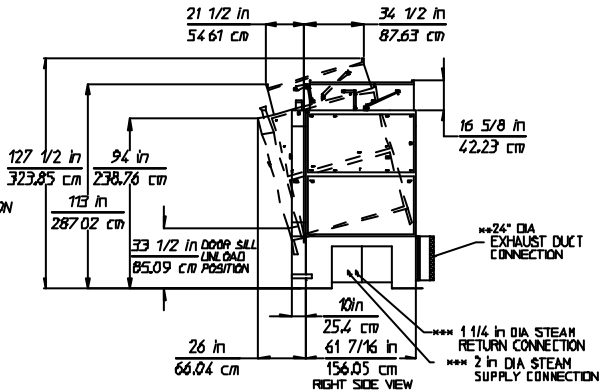
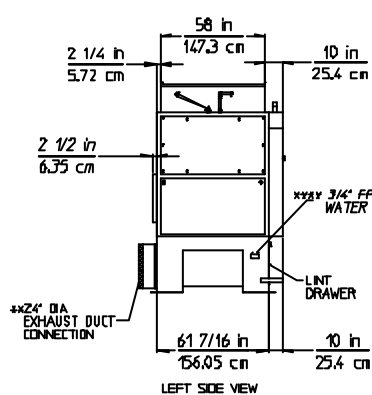
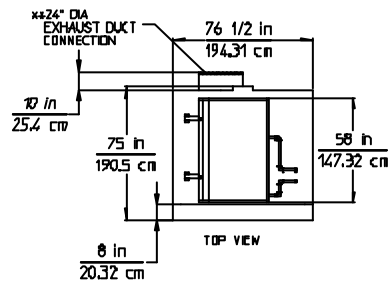
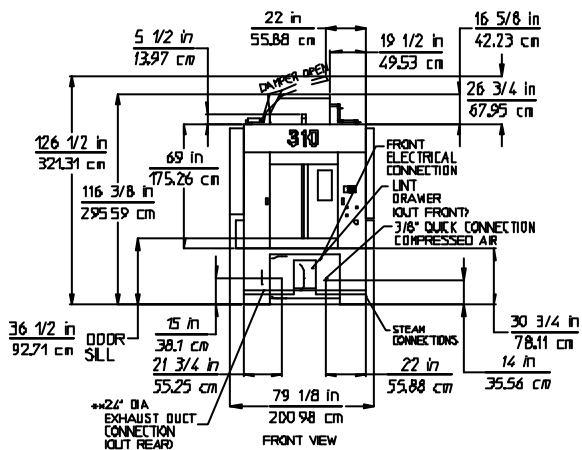

310 TILTING* 1 DOOR / FORWARD AND REAR TILT GAS MODEL

* BOTH GAS AND STEAM TILTING UNITS MUST BE SUPPLIED WITH CLEAN, DRY, REGULATED AIR AT 80 PSI = 10 PSI (5.52 BAR = 69 BAR).
 ** DUCTWORK SIZE VARIES WITH INSTALLATION CONDITIONS. EXHAUST STATIC PRESSURE SHOULD NOT EXCEED 0.3" WATER COLUMN @ 74 MPH.
 *** SIZE OF PIPING TO DRYER VARIES WITH INSTALLATION CONDITIONS. CONTACT FACTORY FOR ASSISTANCE.

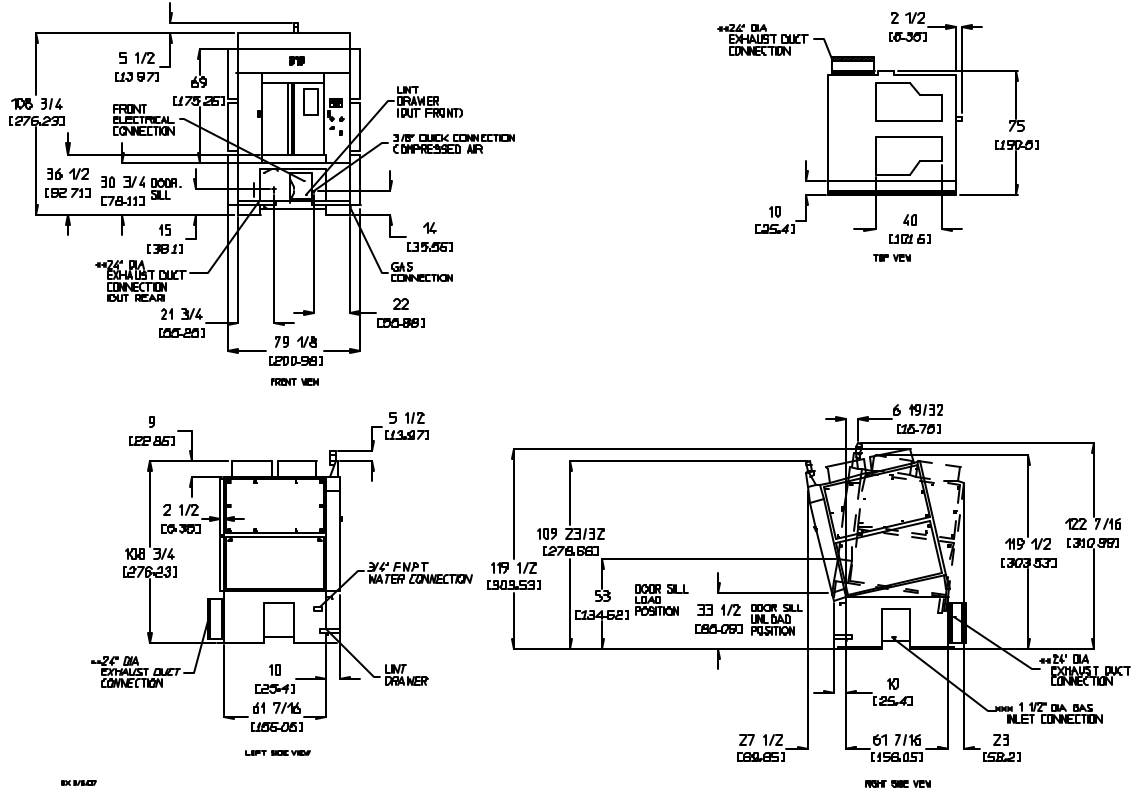

310 TILTING* 1 DOOR / FORWARD AND REAR TILT STEAM MODEL

* BOTH GAS AND STEAM TILTING UNITS MUST BE SUPPLIED WITH CLEAN, DRY, REGULATED AIR AT 80 PSI = 10 PSI (5.52 BAR = 69 BAR).
 ** DUCTWORK SIZE VARIES WITH INSTALLATION CONDITIONS. EXHAUST STATIC PRESSURE SHOULD NOT EXCEED 0.3" WATER COLUMN @ 74 MPH.
 *** SIZE OF PIPING TO DRYER VARIES WITH INSTALLATION CONDITIONS. CONTACT FACTORY FOR ASSISTANCE.

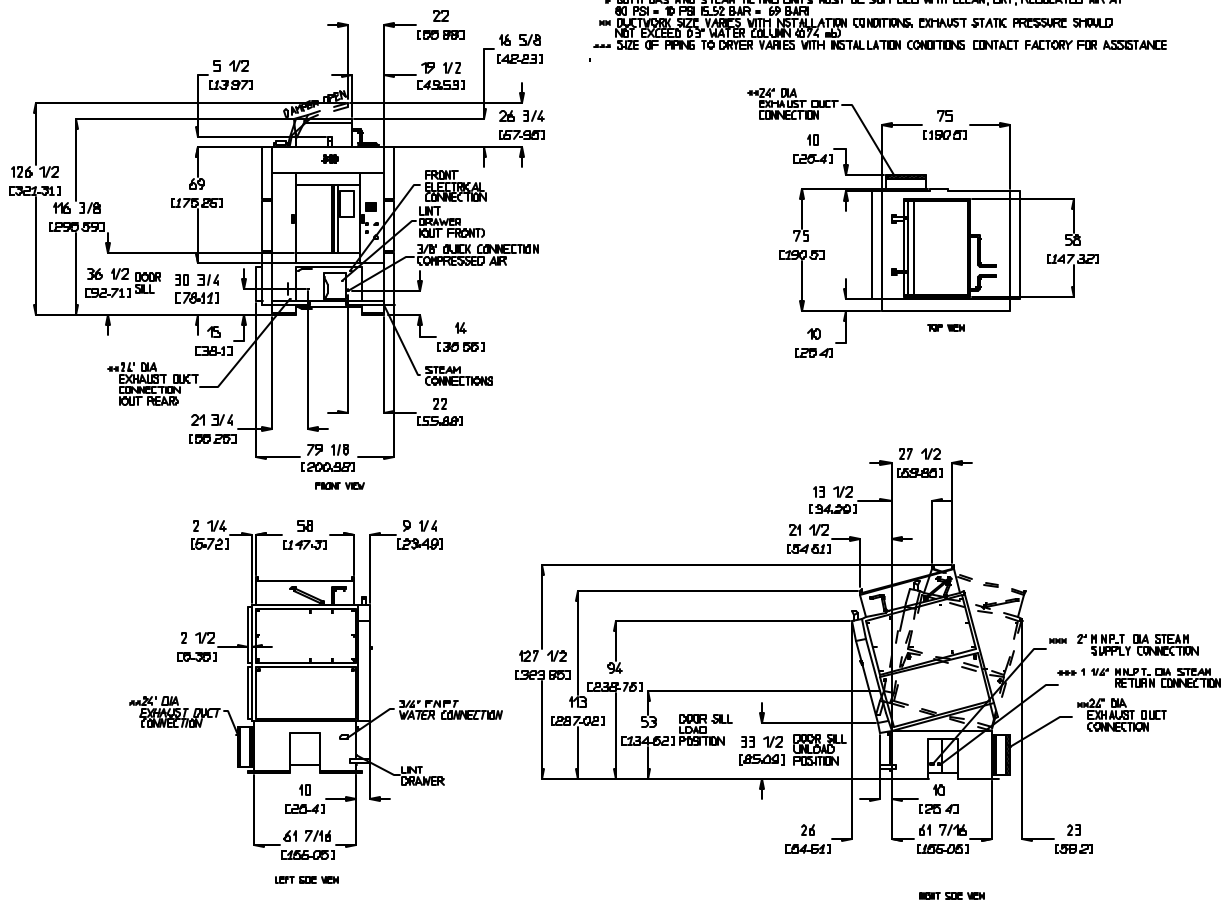

310 TILTING* 2 DOOR/REAR TILT GAS MODEL

- * BOTH GAS AND STEAM TILTING UNITS MUST BE SUPPLIED WITH CLEAN, DRY, REGULATED AIR AT 80 PSI ± 10 PSI (5.52 BAR ± .69 BAR)
- ** DUCTWORK SIZE VARIES WITH INSTALLATION CONDITIONS. EXHAUST STATIC PRESSURE SHOULD NOT EXCEED 0.3" WATER COLUMN (0.74 mB)
- *** SIZE OF PIPING TO DRYER VARIES WITH INSTALLATION CONDITIONS. CONTACT FACTORY FOR ASSISTANCE

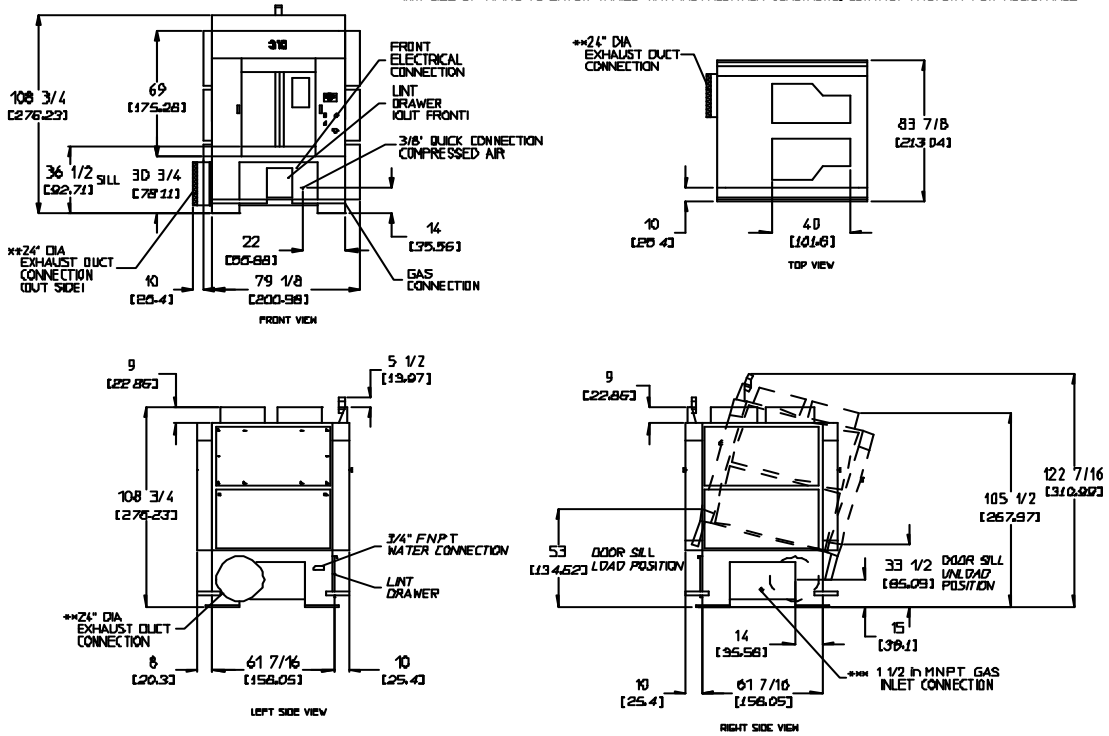

EX 310/2

310 TILTING* 2 DOOR/REAR TILT STEAM MODEL

- * BOTH GAS AND STEAM TILTING UNITS MUST BE SUPPLIED WITH CLEAN, DRY, REGULATED AIR AT 80 PSI ± 10 PSI (5.52 BAR ± .69 BAR)
- ** DUCTWORK SIZE VARIES WITH INSTALLATION CONDITIONS. EXHAUST STATIC PRESSURE SHOULD NOT EXCEED 0.3" WATER COLUMN (0.74 mB)
- *** SIZE OF PIPING TO DRYER VARIES WITH INSTALLATION CONDITIONS. CONTACT FACTORY FOR ASSISTANCE

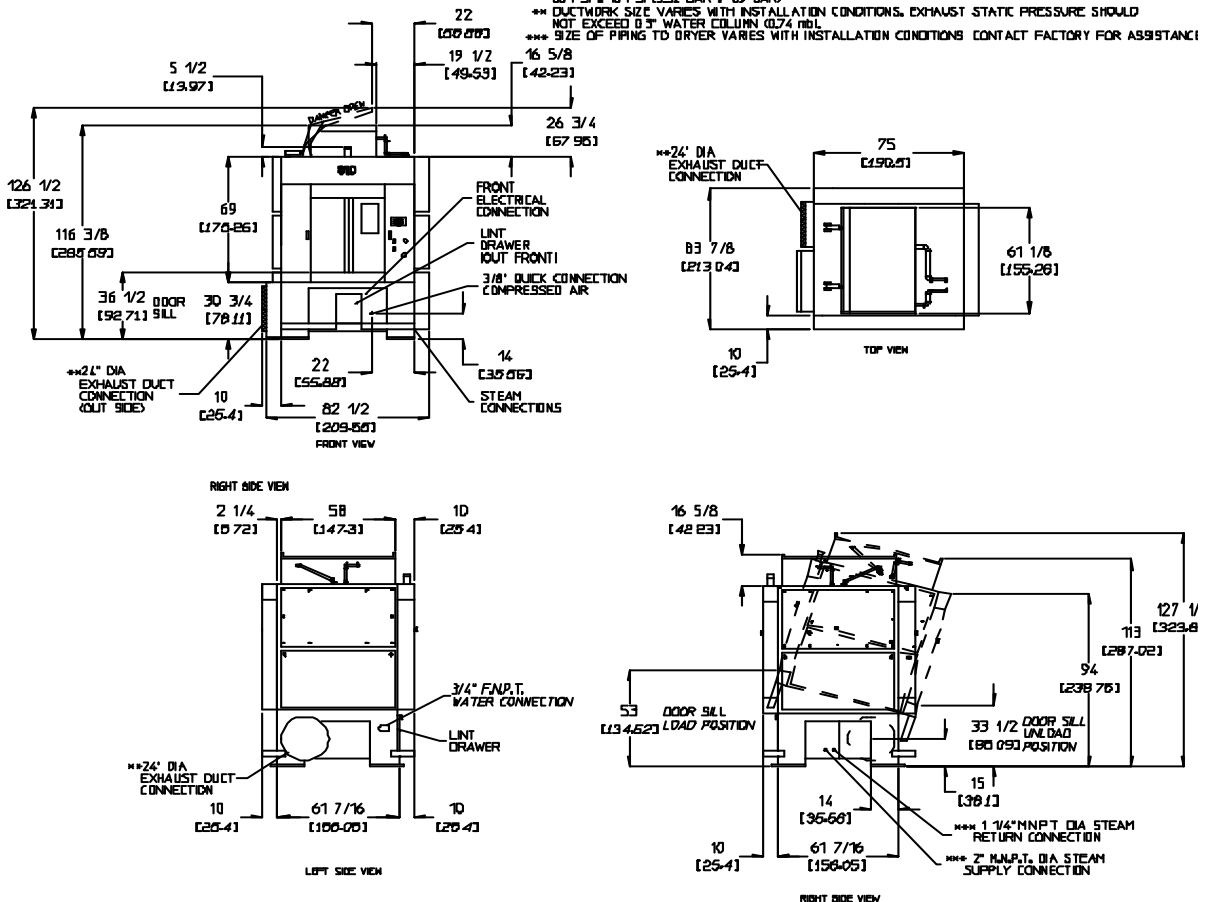



88 Currant Road • Fall River, MA 02720
Tel. 508-678-9000 • Fax 508-678-9447
sales@amdry.com • www.amdry.com